

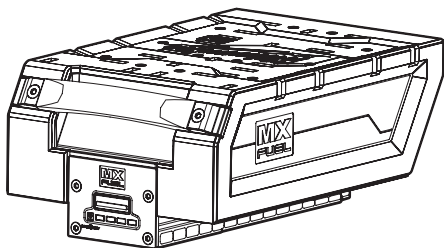

OPERATOR'S MANUAL

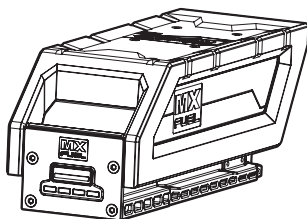
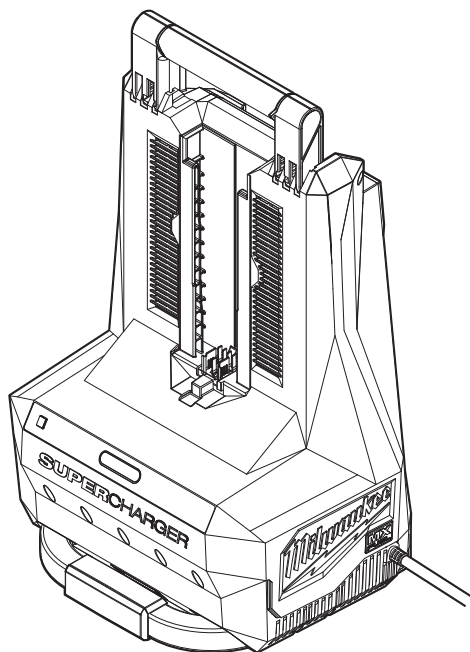

Cat. No.
MXF SC

MX FUEL™ SUPER CHARGER **MX FUEL™ LI-ION BATTERY PACKS**



WARNING



To reduce the risk of injury, user must read and understand operator's manual.



GENERAL POWER TOOL SAFETY WARNINGS

WARNING READ AND UNDERSTAND ALL INSTRUCTIONS.

Failure to follow all instructions listed below, may result in electric shock, fire and/or serious personal injury.

1. **SAVE THESE INSTRUCTIONS** -This manual contains important safety and operating instructions for the **MILWAUKEE® Li-Ion charger and MILWAUKEE® Li-Ion batteries.**

2. Before using the battery pack and charger, read this operator's manual, machine's operator's manual, and all labels on the battery pack, charger and machine.

3. This appliance is not intended for use by persons (including children) with reduced physical, sensory or mental capabilities, or lack of experience and knowledge, unless they have been given supervision or instruction concerning use of the appliance by a person responsible for their safety. Children should be supervised to ensure that they do not play with the appliance.

4. **CAUTION** TO REDUCE THE RISK OF INJURY, CHARGE MILWAUKEE® MX FUEL™ RECHARGEABLE LI-ION BATTERIES ONLY IN MILWAUKEE® MX FUEL™ LI-ION CHARGERS. Other types of batteries may burst causing personal injury and damage. Do not wire a battery pack to a power supply plug or car cigarette lighter. Batteries will be permanently disabled or damaged.

5. **Avoid dangerous environments.** Do not charge battery pack in rain, snow, damp or wet locations. Do not use battery pack or charger in the presence of explosive atmospheres (gaseous fumes, dust or flammable materials) because sparks may be generated when inserting or removing battery pack, possibly causing fire.

6. **Charge in a well ventilated area.** Do not block charger vents. Keep them clear to allow proper ventilation. Do not allow smoking or open flames near a charging battery pack. Vented gases may explode.

7. **Maintain charger cord.** When unplugging charger, pull plug rather than cord. Never carry charger by its cord. Keep cord from heat, oil and sharp edges. Make sure cord will not be stepped on, tripped over or subjected to damage or stress. If the supply cord is damaged, it must be replaced by the manufacturer, its service agent or similarly qualified persons in order to avoid a hazard.

8. **Charger is rated for 100-240V, 50Hz, AC only.** Charger must be plugged into an appropriate outlet.

9. **Use only recommended attachments.** Use of an attachment not recommended or sold by the battery charger or battery manufacturer may result in a risk of fire, electric shock or personal injury.

10. **Unplug charger and remove battery packs** when not in use.

11. **Always unplug charger before cleaning or maintenance.** Do not allow water to flow into unit or batteries. Use a Residual Current Device (RCD) to reduce shock hazards.

12. **Do not burn or incinerate batteries.** Batteries may explode. Toxic fumes and materials are created when batteries are burned.

13. **Do not crush, drop, or damage battery pack. Always securely contain battery packs during transport.** Do not use a battery pack that has received a sharp blow, been dropped, run over, or damaged in any way (e.g., pierced with a nail, hit with a hammer, stepped on, in a vehicle accident).

14. **Do not disassemble battery pack or charger.** If it is damaged, take it to a MILWAUKEE® service facility.

15. **Battery chemicals cause serious burns.** Never allow contact with skin, eyes, or mouth. If a damaged battery pack leaks battery chemicals, use rubber or neoprene gloves to dispose of it. If skin is exposed to battery fluids, wash with soap and water and rinse with vinegar. If eyes are exposed to battery chemicals, immediately flush with water for 20 minutes and seek medical attention. Remove and dispose of contaminated clothing.

16. **Battery chemicals cause serious burns.** Never allow contact with skin, eyes, or mouth. If a damaged battery pack leaks battery chemicals, use rubber or neoprene gloves to dispose of it. If skin is exposed to battery fluids, wash with soap and water and rinse with vinegar. If eyes are exposed to battery chemicals, immediately flush with water for 20 minutes and seek medical attention. Remove and dispose of contaminated clothing.

17. **Do not allow fluids to flow into battery pack.** Corrosive or conductive fluids, such as seawater, certain industrial chemicals, and bleach or bleach containing products, etc., can cause a short circuit. Do not use battery packs that have been exposed to these types of fluids.

18. **To reduce the risk of injury, do not carry battery pack by handle.**

19. **Store your battery pack and charger in a cool, dry place.** Do not store battery pack where temperatures may exceed 50°C (120°F) such as in direct sunlight, a vehicle or metal building during the summer.

20. **Always ship Li-Ion batteries in accordance with the current regulations governing the chosen mode of transport (e.g. ground, air, sea).** When in doubt, contact MILWAUKEE®, the carrier or other trained Dangerous Goods professional to determine applicable regulations.

21. **Maintain labels and nameplates.** These carry important information. If unreadable or missing, contact a MILWAUKEE® service facility for replacement.

22. Rechargeable batteries are to be removed from the appliance before being charged.

23. Exhausted batteries that have reached end-of-life are to be removed from the appliance and safely disposed of.

24. If the appliance is to be stored unused for a long period, the batteries should be removed. Disconnect and remove battery pack before storing.

ADDITIONAL BATTERY SAFETY RULES

⚠WARNING To reduce the risk of fire, personal injury, and product damage due to a short circuit, never immerse your tool, battery pack or charger in fluid or allow a fluid to flow inside them. Corrosive or conductive fluids, such as seawater, certain industrial chemicals, and bleach or bleach-containing products, etc., can cause a short circuit.

⚠WARNING Do not charge non-rechargeable batteries.

SPECIFICATIONS

Charger Cat. No. MXF SC
 Input Volts..... 100-240 V AC
 Input Wattage..... 1200 W
 Output Volts..... 72 V DC
 Max Output Amps..... 12 A DC
 Recommended Ambient Charging Temperature..... 5°C to 40°C
 MX FUEL™ Li-Ion Battery Packs..... 72 V DC

Type	Rated voltage	Rated capacity	Cell type	Cell number
MXFCP203	72V	≤ 3.0 Ah	Li-ion	20
MXFXC406	72V	≤ 6.0 Ah	Li-ion	2 x 20
MXFHD812	72V	≤ 12.0 Ah	Li-ion	3 x 20

SYMBOLGY



Safety Alert



Volts



Direct Current



Hertz



Amps



⚠CAUTION Risk of electric shock



Read operator's manual



Indoor use



Regulatory Compliance Mark (RCM). This product meets applicable regulatory requirements.



Do not dispose of electric tools together with household waste material. Electric tools and electronic equipment that have reached the end of their life must be collected separately and returned to an environmentally compatible recycling facility.

FUNCTIONAL DESCRIPTION

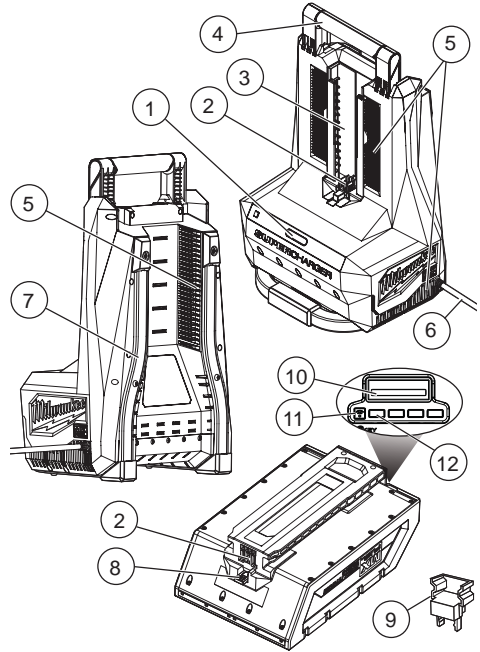

1. Charger light indicators
2. Charger/Battery contacts
3. Battery Bay
4. Handle
5. Vents
6. Supply Cord
7. Roll cage
8. Shipping switch
9. Shipping cap
10. Fuel gauge button
11. ONE-KEY™ indicator
12. Fuel gauge

MX FUEL™ LI-ION BATTERY PACKS

Fuel Gauge

The battery packs are shipped in "sleep" mode and must be charged before first use.

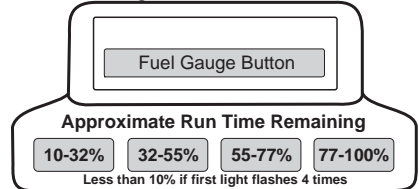

Use the Fuel Gauge to determine the battery pack's remaining run time. Press the Fuel Gauge button to display the lights. The Fuel Gauge will light up for 2-3 seconds. When less than 10% of charge is left, 1 light on the fuel gauge will flash 4 times. When the battery reaches 0% charge, 1 light on the fuel gauge will flash 8 times. Charge the battery pack.

An alternating blinking pattern indicates that an error or overtemperature state was encountered. Allow the battery pack to cool and reinsert. If the pattern continues, contact a *MILWAUKEE*[®] service facility.

The Fuel Gauge will not work when the shipping switch is pulled out of a battery with a shipping switch.

If the Fuel Gauge doesn't appear to be working, place the battery pack on the charger and charge as needed.

Immediately after using the battery pack, the Fuel Gauge may display a lower charge than it will if checked a few minutes later. The battery cells "recover" some of their charge after resting.

Under extreme circumstances, the internal temperature of the battery could become too high. If this happens, the fuel gauge lights will flash in an alternating pattern and the product will not run. Allow the battery to cool down.

Fuel Gauge Lights	Diagnosis	Solution
Lights 1 - 4 Solid	Remaining runtime	Continue working.
1 Light, flashing slowly	Less than 10% runtime left	Prepare to charge battery pack.
1 Light, flashing quickly	End of discharge	Charge battery pack.
Lights 1-4, flashing quickly	Current draw too high	Release trigger. Once fuel gauge has stopped flashing, restart and reduce pressure.
Lights 1&3 / 2&4, flashing alternatingly	Battery temperature too high	Release trigger and allow battery to cool.
Lights 1&4 / 2&3, flashing alternatingly	Communication error	Remove the battery. Press the Fuel Gauge button to clear. Reinsert the battery. [†]

[†] If the problem persists, take the product, charger, and battery pack to a *MILWAUKEE*[®] service facility.

Battery Pack Protection

To protect itself from damage and extend its life, the battery pack's intelligent circuit monitors current draw and temperature. In extremely high torque, binding, stalling, and short circuit situations, the battery pack will turn OFF the product if the current draw becomes too high. The fuel gauge will flash. Release the trigger, wait for the fuel gauge to stop flashing, and then restart.

ONE-KEY™



Do not ingest battery.



Chemical Burn Hazard.

This device contains a lithium button/coin cell battery. A new or used battery can cause severe internal burns and lead to death in as little as 2 hours if swallowed or enters the body. Always secure the battery cover. If it does not close securely, stop using the device, remove the batteries, and keep it away from children. If you think batteries may have been swallowed or entered the body, seek immediate medical attention.



An internal battery is used to facilitate full ONE-KEY™ functionality. The internal battery is located on the bottom of the rear housing.

To replace the battery:

1. Remove the screw and open the battery door.
2. Remove the old battery, keep it away from children, and dispose of it properly.

An internal battery is used to facilitate full ONE-KEY™ functionality. The internal battery is located on the bottom of the rear housing.

To replace the battery:

1. Remove the screw and open the battery door.
2. Remove the old battery, keep it away from children, and dispose of it properly.

3. Insert the new battery (3V CR2032), with the positive side facing up.

4. Close the battery door and tighten the screw securely.

Cold Weather Operation

MILWAUKEE[®] Li-Ion battery packs are designed to operate in temperatures below freezing. When the battery pack is too cold, it may need to warm up before normal use. Put the battery on a product and use the product in a light application.



To reduce the risk of injury or explosion, never burn or incinerate a battery pack even if it is damaged, dead or completely discharged. When burned, toxic fumes and materials are created.

Disposing of *MILWAUKEE*[®] Li-Ion Battery Packs

MILWAUKEE[®] Li-Ion battery packs are more environmentally friendly than some other types of power tool battery packs (e.g., nickel-cadmium). Always dispose of battery packs according to federal, state and local regulations. Contact a recycling agency for recycling locations.

Even discharged battery packs contain some energy. Before disposing, use electrical tape to cover the terminals to prevent the battery pack from shorting, which could cause a fire or explosion.

MX FUEL™ LI-ION CHARGER

⚠WARNING Charge only MILWAUKEE® MX FUEL™ Li-Ion batteries in this MILWAUKEE® Li-Ion charger. Other types of batteries may cause personal injury and damage.

When to Charge the Battery Pack with this MILWAUKEE® Charger

Remove the battery pack from the tool for charging when convenient. MILWAUKEE® batteries do not develop a "memory" when charged after only a partial discharge. It is not necessary to run down the battery pack before placing it on the charger.





- Use the Fuel Gauge to determine when to charge your MILWAUKEE® Li-Ion battery pack.
- You can "Top-Off" your battery pack's charge before starting a big job or long day of use.
- The only time it is necessary to charge the MILWAUKEE® Li-Ion battery pack is when the battery pack has reached the end of its charge. To signal the end of charge, power to the tool will drop quickly, allowing enough power to finish making a cut, drilling a hole, or driving a fastener. Charge the battery packs as needed.

How to Charge the Battery Pack

Align the battery pack with the bay and slide the battery pack into the charger as far as possible. The red light will come on, either flashing quickly (battery pack or charger is too hot or cold), flashing slowly (communication between pack and charger) or continuous (pack is charging).

- A fully discharged battery pack with an internal temperature in the normal range will charge in about 35 to 75 minutes, depending on the battery pack and internal temperature of the charger.
- Heavily cycled batteries may take longer to charge completely.
- The fuel gauge lights are displayed as the pack is being charged, indicating how fully charged the pack is. The fuel gauge will turn off when charging is complete.
- After charging is complete, the continuous green light will come on.
- If the light indicator flashes red and green, check that the battery pack is fully seated into the bay. Remove the battery pack and reinsert. If the light continues to flash red and green, remove pack(s) and unplug charger for at least 2 minutes. After 2 minutes, plug charger back in and insert pack. If the problem persists, contact a MILWAUKEE® service facility.
- If the light indicator does not come on, check that the battery pack is fully seated into the bay. Remove the battery pack and reinsert. If the light indicator still does not come on, remove pack(s) and unplug charger for at least 2 minutes. After 2 minutes, plug charger back in and insert pack. If after these attempts the light indicator still does not come on, contact a MILWAUKEE® service facility.

The LED on the battery indicates the state of charge:

	Continuous red	Charging
	Slow flashing green	Approaching full charge
	Continuous green	Charging is complete
	Fast flashing red	Battery and/or charger is too hot/cold – charging will begin when battery and/or charger reach correct charging temperature.
	Flashing red/green	Damaged or faulty battery pack and/or charger.

Charging a Hot or Cold Battery Pack

The fast Red Flashing Indicator light on the charger indicates that the battery pack or charger temperature is outside the charging range. Once the battery pack or charger is within the acceptable range, normal charging will take place and the red light will be continuous. Hot or cold batteries may take longer to charge.

Battery Pack or Charger Temperature	Red Charger Indicator Light	Charging Status
Too Hot	Fast Flashing	Not charging
Normal Range	Continuous	Normal charging
Too Cold	Fast Flashing	Not charging

Powering the Charger with an Inverter or Generator

The charger will operate with most 230V generators and inverters rated at 1,500 Watts or higher.

MAINTENANCE

⚠WARNING To reduce the risk of fire, personal injury, and product damage due to a short circuit, never immerse a tool, battery pack or charger in fluid or allow a fluid to flow inside them. Corrosive or conductive fluids, such as seawater, certain industrial chemicals, and bleach or bleach containing products, etc., can cause a short circuit.

Always unplug the charger and remove the battery from the charger before performing any maintenance. Never disassemble the battery or charger. Contact a MILWAUKEE® service facility for ALL repairs.

Cleaning

Do not expose battery packs, chargers or tools to fluids, water, or rain, or allow them to get wet. This could damage the tool, charger, and/or battery pack. Clean out dust and debris from tool, charger and battery vents and electrical contacts by vacuuming or brushing. Clean housings with a damp, soapy cloth, keeping away from all electrical contacts. Certain cleaners and solvents, such as petrol, turpentine, lacquer thinner, paint thinner, bleach, chlorinated cleaning solvents, ammonia and household detergents containing ammonia, are harmful to plastics and other insulated parts; plastic casings will become brittle and crack. Never use flammable or combustible solvents around batteries, charger, or tools.

Storage

As a general practice, it is best to unplug chargers and remove battery packs when not in use, however, no damage to the battery pack will occur. Store at room temperature away from moisture. Store batteries upright. Do not store in damp locations where corrosion of terminals may occur. Storing in high temperatures (over 50°C) for long periods can result in permanent capacity loss for any battery. Charge before use after storing for long periods.

Repairs

For repairs, return the machine to the nearest authorised service centre.

Earth Continuity Testing

In order to complete ANZ testing and tagging to AS/NZS 3760, there is an access point located at the rear of the charger indicating an earth access point. This point can be used to ensure there is a suitable connection between the earth pin on the supply plug and the earthed internal metal.

WARRANTY - AUSTRALIA and NEW ZEALAND

Please refer to Australian and New Zealand warranty supplied with tool. This warranty applies only to product sold by authorised dealers in Australia and New Zealand.

SERVICE - AUSTRALIA and NEW ZEALAND

MILWAUKEE® prides itself in producing a premium quality product that is Nothing But Heavy Duty™. Your satisfaction with our products is very important to us! If you encounter any problems with the operation of this tool, please contact your authorised **MILWAUKEE®** dealer.

For a list of **MILWAUKEE®** dealers, guarantee or service agents please contact **MILWAUKEE®** Customer Service or visit our website.

(Australia Toll Free Telephone Number 1300 645 928)

(New Zealand Toll Free Telephone Number 0800 645 928)

or visit milwaukeetool.com.au/milwaukeetool.co.nz.

Milwaukee Electric Tool Corporation

13135 West Lisbon Road, Brookfield, Wisconsin U.S.A. 53005

Milwaukee Tool (Australia)

26 - 40 Nina Link, Dandenong South,
Victoria, 3175, Australia

Milwaukee Tool (New Zealand)

274 Church Street, Penrose,
Auckland, 1061, New Zealand

DESIGNED BY MILWAUKEE ELECTRIC TOOL CORP.

PROFESSIONALLY MADE IN CHINA

PRINTED IN CHINA