

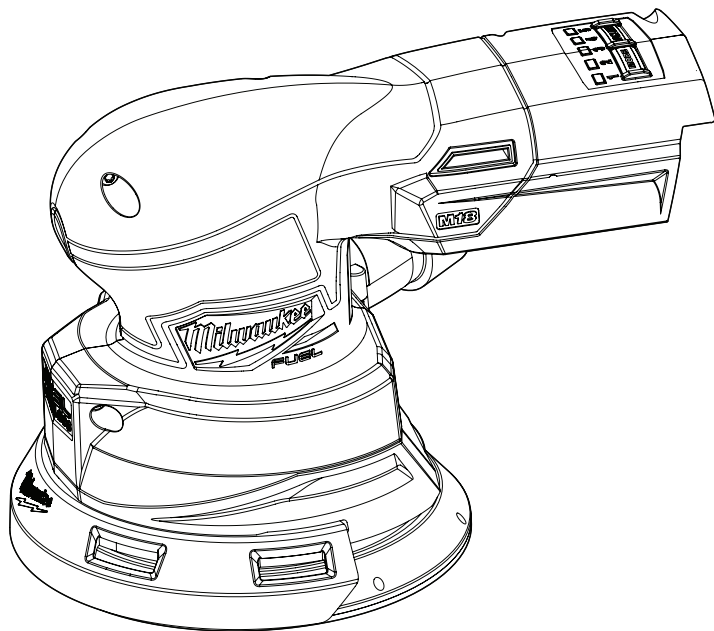



OPERATOR'S MANUAL



Cat. No.
M18 FROS125

M18 FUEL™ 125MM RANDOM ORBITAL SANDER W/ VACLINK™

 **WARNING**

 To reduce the risk of injury, user must read and understand operator's manual.

GENERAL POWER TOOL SAFETY WARNINGS

WARNING Read all safety warnings, instructions, illustrations and specifications provided with this power tool. Failure to follow all instructions listed below may result in electric shock, fire and/or serious injury. **Save all warnings and instructions for future reference.** The term "power tool" in the warnings refers to your mains-operated (corded) power tool or battery-operated (cordless) power tool.

WORK AREA SAFETY

- **Keep work area clean and well lit.** Cluttered or dark areas invite accidents.
- **Do not operate power tools in explosive atmospheres, such as in the presence of flammable liquids, gases or dust.** Power tools create sparks which may ignite the dust or fumes.
- **Keep children and bystanders away while operating a power tool.** Distractions can cause you to lose control.

ELECTRICAL SAFETY

- **Power tool plugs must match the outlet. Never modify the plug in any way. Do not use any adapter plugs with earthed (grounded) power tools.** Unmodified plugs and matching outlets will reduce risk of electric shock.
- **Avoid body contact with earthed or grounded surfaces, such as pipes, radiators, ranges and refrigerators.** There is an increased risk of electric shock if your body is earthed or grounded.
- **Do not expose power tools to rain or wet conditions.** Water entering a power tool will increase the risk of electric shock.
- **Do not abuse the cord. Never use the cord for carrying, pulling or unplugging the power tool. Keep cord away from heat, oil, sharp edges or moving parts.** Damaged or entangled cords increase the risk of electric shock.
- **When operating a power tool outdoors, use an extension cord suitable for outdoor use.** Use of a cord suitable for outdoor use reduces the risk of electric shock.
- **If operating a power tool in a damp location is unavoidable, use a residual current device (RCD) protected supply.** Use of a RCD reduces the risk of electric shock.

PERSONAL SAFETY

- **Stay alert, watch what you are doing and use common sense when operating a power tool. Do not use a power tool while you are tired or under the influence of drugs, alcohol or medication.** A moment of inattention while operating power tools may result in serious personal injury.
- **Use personal protective equipment. Always wear eye protection.** Protective equipment such as a dust mask, non-skid safety shoes, hard hat or hearing protection used for appropriate conditions will reduce personal injuries.
- **Prevent unintentional starting. Ensure the switch is in the off-position before connecting to power source and/or battery pack, picking up or carrying the tool.** Carrying power tools with your finger on the switch or energising power tools that have the switch on invites accidents.

- **Remove any adjusting key or wrench before turning the power tool on.** A wrench or a key left attached to a rotating part of the power tool may result in personal injury.
- **Do not overreach. Keep proper footing and balance at all times.** This enables better control of the power tool in unexpected situations.
- **Dress properly. Do not wear loose clothing or jewellery. Keep your hair and clothing away from moving parts.** Loose clothes, jewellery or long hair can be caught in moving parts.
- **If devices are provided for the connection of dust extraction and collection facilities, ensure these are connected and properly used.** Use of dust collection can reduce dust-related hazards.
- **Do not let familiarity gained from frequent use of tools allow you to become complacent and ignore tool safety principles.** A careless action can cause severe injury within a fraction of a second.

POWER TOOL USE AND CARE

- **Do not force the power tool. Use the correct power tool for your application.** The correct power tool will do the job better and safer at the rate for which it was designed.
- **Do not use the power tool if the switch does not turn it on and off.** Any power tool that cannot be controlled with the switch is dangerous and must be repaired.
- **Disconnect the plug from the power source and/or remove the battery pack, if detachable, from the power tool before making any adjustments, changing accessories, or storing power tools.** Such preventive safety measures reduce the risk of starting the power tool accidentally.
- **Store idle power tools out of the reach of children and do not allow persons unfamiliar with the power tool or these instructions to operate the power tool.** Power tools are dangerous in the hands of untrained users.
- **Maintain power tools and accessories. Check for misalignment or binding of moving parts, breakage of parts and any other condition that may affect the power tool's operation. If damaged, have the power tool repaired before use.** Many accidents are caused by poorly maintained power tools.
- **Keep cutting tools sharp and clean.** Properly maintained cutting tools with sharp cutting edges are less likely to bind and are easier to control.
- **Use the power tool, accessories and tool bits etc. in accordance with these instructions, taking into account the working conditions and the work to be performed.** Use of the power tool for operations different from those intended could result in a hazardous situation.
- **Keep handles and grasping surfaces dry, clean and free from oil and grease.** Slippery handles and grasping surfaces do not allow for safe handling and control of the tool in unexpected situations.

BATTERY TOOL USE AND CARE

- **Recharge only with the charger specified by the manufacturer.** A charger that is suitable for one type of battery pack may create a risk of fire when used with another battery pack.
- **Use power tools only with specifically designated battery packs.** Use of any other battery packs may create a risk of injury and fire.

- When battery pack is not in use, keep it away from other metal objects, like paper clips, coins, keys, nails, screws or other small metal objects, that can make a connection from one terminal to another. Shorting the battery terminals together may cause burns or a fire.
- Under abusive conditions, liquid may be ejected from the battery; avoid contact. If contact accidentally occurs, flush with water. If liquid contacts eyes, additionally seek medical help. Liquid ejected from the battery may cause irritation or burns.
- Do not use a battery pack or tool that is damaged or modified. Damaged or modified batteries may exhibit unpredictable behaviour resulting in fire, explosion or risk of injury.
- Do not expose a battery pack or tool to fire or excessive temperature. Exposure to fire or temperature above 130°C (265°F) may cause explosion.
- Follow all charging instructions and do not charge the battery pack or tool outside the temperature range specified in the instructions. Charging improperly or at temperatures outside the specified range may damage the battery and increase the risk of fire.

SERVICE

- Have your power tool serviced by a qualified repair person using only identical replacement parts. This will ensure that the safety of the power tool is maintained.
- Never service damaged battery packs. Service of battery packs should only be performed by the manufacturer or authorised service providers.

SPECIFIC SAFETY RULES FOR SANDERS

- WARNING** To reduce the risk of injury from moving parts, do not operate tool with backing pad removed.
- WARNING** To reduce the risk of injury, when working in dusty situations, wear appropriate respiratory protection or use a suitable dust extraction solution.
- Do not use sandpaper intended for larger sanding pads. Larger sandpaper will extend beyond the sanding pad causing snagging, tearing of the paper, or kickback. Extra paper extending beyond the sanding pad can also cause serious lacerations.
- The rated speed of the backing pad must be at least equal to the maximum speed marked on the power tool. Accessories running faster than their rated speed can break and fly apart.
- Do not wet-sand with this sander. Water entering a power tool will increase the risk of electric shock.
- To reduce the risk of injury, do not use this tool for sanding or refinishing automotive brake pads or brake rotors. Some dust created by power sanding, sawing, grinding, drilling, and other construction activities contains chemicals known to cause cancer, birth defects, or other reproductive harm.
- Collected sanding dust from sanding surface coatings such as polyurethanes, linseed oil, etc. can self-ignite in the sander dust bag or elsewhere and cause fire. To reduce the risk of fire always empty the dust bag frequently (10-15 minutes) while sanding and never store or leave a

sander without totally emptying its dust bag. Also follow the recommendations of the coatings manufacturers.

- Always use common sense and be cautious when using tools. It is not possible to anticipate every situation that could result in a dangerous outcome. Do not use this tool if you do not understand these operating instructions or you feel the work is beyond your capability; contact MILWAUKEE® Tool or a trained professional for additional information or training.
- Maintain labels and nameplates. These carry important information. If unreadable or missing, contact a MILWAUKEE® service facility for a replacement.

- WARNING** Some dust created by power sanding, sawing, grinding, drilling, and other construction activities contains chemicals known to cause cancer, birth defects or other reproductive harm. Some examples of these chemicals are:
 - lead from lead-based paint
 - crystalline silica from bricks and cement and other masonry products, and
 - arsenic and chromium from chemically-treated lumber.

Your risk from these exposures varies, depending on how often you do this type of work. To reduce your exposure to these chemicals: work in a well ventilated area, and work with approved safety equipment, such as those dust masks that are specially designed to filter out microscopic particles.

READ AND SAVE ALL INSTRUCTIONS FOR FUTURE USE

ADDITIONAL BATTERY SAFETY RULES

- WARNING** To reduce the risk of fire, personal injury, and product damage due to a short circuit, never immerse your tool, battery pack or charger in fluid or allow a fluid to flow inside them. Corrosive or conductive fluids, such as seawater, certain industrial chemicals, and bleach or bleach-containing products, etc., can cause a short circuit.

- WARNING** Do not charge non-rechargeable batteries.

SYMBOLGY



Volts



Direct Current



Orbits per Minute (OPM)



Tool has VACLINK™ technology



Read Operator's Manual



Regulatory Compliance Mark (RCM). This product meets applicable regulatory requirements.



Do not dispose of electric tools together with household waste material. Electric tools and electronic equipment that have reached the end of their life must be collected separately and returned to an environmentally compatible recycling facility.

SPECIFICATIONS

Cat. No.	M18 FROS125
Volts	18 V DC
Battery Type	M18™
Charger Type	M18™
Disc Size	125 mm (5")
Orbit Diameter	2.5mm (3/32")
Orbits Per Min	6,000-12,000
Backing Pad	Hook and Loop
Replacement Backing Pad Cat. No.	49362837
Vacuum Hose Compatibility	32 mm (1-1/4"), 47.6 mm (1-7/8"), 63.5 mm (2-1/2")

Recommended Ambient
Operating Temperature..... -17°C to 51°C

FUNCTIONAL DESCRIPTION

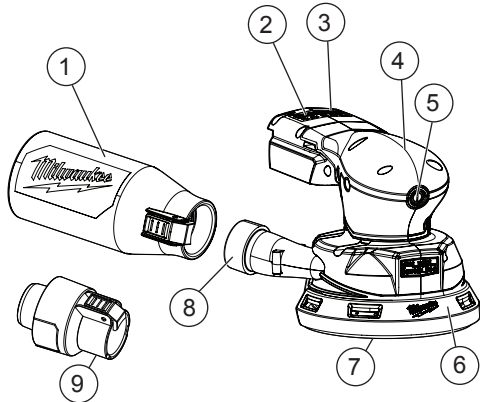

- | | |
|----------------------------|---------------------------|
| 1. Dust bag | 5. ON/OFF button |
| 2. VACLINK™ pairing button | 6. Edge guard |
| 3. MODE button | 7. Backing pad |
| 4. Hand grip | 8. Dust port |
| | 9. Universal hose adaptor |

ASSEMBLY

⚠WARNING Recharge only with the charger specified for the battery. For specific charging instructions, read the operator's manual supplied with your charger and battery.

Inserting/Removing the Battery

To insert the battery, slide the pack into the body of the tool. Make sure it latches securely into place.

⚠WARNING Only use accessories specifically recommended for this tool. Others may be hazardous.

To remove the battery, push in the release buttons and pull the battery pack away from the tool.

⚠WARNING Always remove the battery pack any time the tool is not in use.

Selecting Sandpaper and Grits

Sandpaper can be made from various grit materials and these should be selected according to the material to be sanded. The guidelines below list materials and grit materials that should be used with them.

- **Fine woodwork** – garnet or aluminium oxide
- **Rough woodwork** – aluminium zirconia or ceramic aluminium oxide

• **Manufactured wood products** (particleboard, medium density fiber board, etc.) – silicon carbide or aluminium oxide

• **Solid surface materials** (Corian®, quartz, granite, etc.) – silicon carbide or aluminium oxide

• **Metals** – emery or aluminium oxide

Sandpaper is also graded by coarseness. Start your work with an abrasive grit just coarse enough to remove high spots and excessive roughness. Follow with a second sanding using a grit one or two grades finer. Continue with successively finer grits until you obtain the desired finish.

Do not switch from a coarse grit to a very fine grit in one step because it may be difficult to remove the marks made by the coarse grit abrasive. Use the finest grits practical for the roughing operation, and finish by using successively finer grits.

Grit	Type	Typical Application
60 80	Coarse	Ideal for initial sanding on rougher surfaces. For fast stock removal. Rough sanding and stripping of painted and rusted surfaces.
100 120	Medium	For intermediate sanding and removal of minor surface imperfections.
150 180 220	Fine	Ideal for fine sanding prior to straining, priming, or sealing.
400	Ultra Fine	Ideal for final sanding.

Attaching/Removing Hook and Loop Sanding Discs

NOTICE If you use sanding sheets that have no holes or that have holes in an incompatible orientation, there will be little or no dust collection by the sander.

Hook and Loop type sanding discs can be reused for the life of the sanding abrasive.

1. **⚠WARNING** Remove battery to avoid starting the tool.
2. To attach, align the holes of the sanding disc with the holes in the backing pad. Holes in sanding disc must line up with holes in the backing pad for dust collection.
3. Press the disc against the pad as tightly as possible.
4. Clean the backing pad occasionally by brushing lightly with a soft nylon brush or compressed air. Dust buildup on backing pad could cause sanding discs to not hold properly.
5. To remove, pull the sanding disc off of the backing pad.

Changing the Backing Pad

The sander comes assembled with the hook and loop pad. To attach a pressure sensitive adhesive (PSA) pad (not included), first remove the hook and loop pad. Inspect backing pad before installing. Do not use if broken or defective.

1. **⚠WARNING** Remove battery to avoid starting the tool.

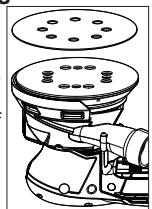

- Remove the four screws that hold the hook and loop pad in place.
- Remove the hook and loop pad.
- Clean dust particles from the pad brake.
- Apply a thin layer of lightweight grease to the back of the pad.

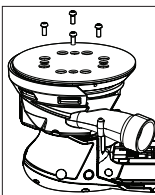

- Align the holes in the pressure sensitive adhesive (PSA) pad with the four screw holes in the sander.
- Replace the four screws securely.

Attaching/Removing PSA Sanding Discs

- WARNING** Remove battery to avoid starting the tool.
- Carefully peel away the paper backing from the new pressure sensitive adhesive (PSA) sanding disc.
- To **attach**, align the holes of the sanding disc with holes in the backing pad. Holes in sanding disc must line up with holes in the backing pad for dust collection.
- Press the disc against the pad as tightly as possible.
- Clean the backing pad occasionally by brushing lightly with a small brush. Dust buildup on backing pad could cause sanding discs to not stick properly.
- To **remove**, peel the sanding disc off of the backing pad. The abrasive sanding disc may tear when removing. If this occurs, sand for a few minutes to soften the adhesive backing try to remove it again.
- Remove sanding discs before storage. If the sanding disc is left on the backing pad after using for an extended amount of time, the abrasive sanding disc adhesive will cause the sanding disc to become difficult to remove.

Attaching/Removing Edge Guard

- WARNING** Remove battery to avoid starting the tool.
- To **attach**, align both corner ridges of the edge guard with the guide slot on the front of the tool. Push the edge guard in until it is firmly attached to the tool.
- To **remove**, pull a corner of the edge guard outward and away from the tool. Once loosened, pull the entire edge guard away from the tool.

WARNING Collected sanding dust from sanding surface coatings such as polyurethanes, linseed oil, etc. can self-ignite in the sander dust box or elsewhere and cause fire. To reduce the risk of fire always empty the dust bag frequently (10-15 minutes) while sanding and never store or leave a sander without totally emptying its dust bag. Also follow the recommendations of the coatings manufacturers.

Do not use the dust bag when sanding metal. This causes a fire hazard and can result in serious injury.

Attaching The Dust Bag

The dust bag provides a dust collection system for the sander. Sanding dust is drawn up through the holes of the sanding disc and collected in the dust bag during sanding.

To use the dust bag:

- WARNING** Remove battery to avoid starting the tool.

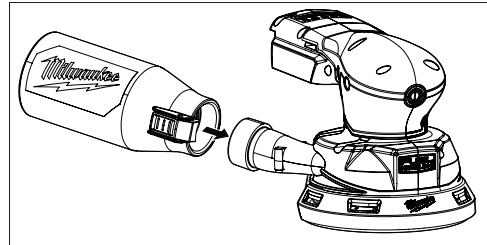

- To **insert**, push the tab in the open position while sliding the dust bag into the sander's dust port.
- To **remove**, grasp the sander and dust box firmly and push the tab in the open position while pulling the dust bag away from the sander's dust port.
- To empty, refer to the "Emptying the Dust Bag" section.

NOTE: For more efficient operation, empty the dust bag when it is no more than half full. This will allow the air to flow better through the dust bag. Always empty thoroughly upon completion of a sanding operation and before storing the sander.

WARNING When sander is not connected to vacuum, always reinstall dust bag assembly back onto sander. Failure to do so could cause sanding dust or foreign objects to be thrown into face or eyes which could result in possible serious injury.

Universal Hose Adaptor

Use the universal hose adaptor to attach the sander to a vacuum hose.

- WARNING** Remove battery to avoid starting the tool.
- Remove the dust bag from the sander.
- To **insert**, slide the universal hose adaptor into the sander's dust port. Push sander and adaptor together firmly. Connect the vacuum hose to the adaptor.
- To **remove**, disconnect the vacuum hose from the adaptor. Then, grasp the sander and adaptor firmly and pull apart.

For use with the Dust Extractor

For dust extractor assembly and operation, refer to the manufacturer's dust extractor manual.

OPERATION

WARNING To reduce the risk of injury, always remove battery pack before changing or removing accessories or making adjustments. Only use accessories specifically recommended for this tool. Others may be hazardous. Always use personal protective equipment.

WARNING To reduce the risk of injury, always wear proper eye protection marked to comply with AS/NZS 1337.1. When working in dusty situations, wear appropriate respiratory protection or use a suitable dust extraction solution. Finish sanding can produce clouds of fine dust that could ignite in the presence of sparks or open flame. Always wear a suitable dust mask or respirator and use the sander in a well-ventilated area.

To reduce the risk of injury, inspect for and remove all raised nails and fasteners from workpiece before sanding. Striking a fastener while sanding could cause loss of control.

Adjusting the Speed

The sander can be operated at variable speeds - from low speed (1) to high speed (5).

1. To increase sanding disc speed, press the Mode button to a higher number setting.
2. To decrease sanding disc speed, press the Mode button to a lower number setting.

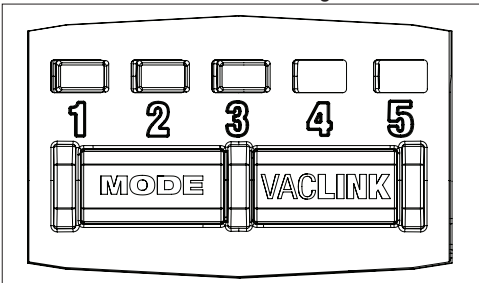

Speed	1	2	3	4	5
OPM	6,000	7,500	9,000	10,000	12,000

Starting and Stopping the Tool

To **start** the sander, press and hold the ON/OFF button.

To **stop** sander, press and hold the ON/OFF button again.

VACLINK™

VACLINK™ is an integrated wireless dust control technology that allows a compatible tool and vacuum/dust extractor (vacuum) to connect to each other.

A signal from the tool will turn the vacuum on and off. The tool can be connected to one vacuum at a time.

NOTE: Other product's VACLINK™ functionality may differ. See those instructions for more information.

Pairing/Unpairing VACLINK™

1. Install a battery pack on the tool and connect the vacuum to a power source.

2. To pair, press and hold the pairing buttons on the tool and vacuum each for >1 second.

VACLINK™ LED:

- Searching - Flashing green
- Paired - Solid green

3. See troubleshooting if tool and vacuum do not pair successfully.

4. To unpair, press and hold the pairing button on the tool for >1 second.

VACLINK™ LED:

- Unpaired - off

When using VACLINK™, one person must control both the vacuum and the paired tool. If the vacuum becomes clogged, the operator must be able to turn the vacuum off to prevent damage to the vacuum.

1. Once paired, set up the vacuum hose, work area, and job as needed, following the tool and vacuum instructions.

2. Turn on the tool. VACLINK™ will automatically turn on the vacuum.

3. Turn off the tool and the vacuum will automatically turn off within a few seconds.

Pausing VACLINK™

VACLINK™ can be paused to halt the connection. NOTE: When the tool's battery pack is removed and then reinstalled, the pause is cancelled and the VACLINK™ will be active.

To pause or unpair, quickly press and release the pairing button (<1 second).

VACLINK™ LED:

- Paused - Flashes red, then off
- Unpaired - Flashes green, then off

Troubleshooting

Pairing is unsuccessful.	Remove battery from tool and power from vacuum for 1 minute. Retry the pairing procedure.
	Check the vacuum is in range of tool. Retry the pairing procedure.
	Move tool and vacuum to an area with lower wireless traffic. Retry the pairing procedure.
	If VACLINK™ is still unable to pair, contact authorised MILWAUKEE® service centre.
Vacuum not turning on/off automatically.	VACLINK™ is paused on the tool. Unpause VACLINK™.
	The vacuum is not connected to a power supply. Connect vacuum to a power supply.
	The tool and vacuum are out of range of each other. Move vacuum and tool closer.
	If VACLINK™ still does not turn the vacuum on/off, unpair and re-pair the tool and vacuum.
	If VACLINK™ still does not turn the vacuum on/off, contact authorised MILWAUKEE® service centre.

General Sanding with Random Orbit Sanders

When using random orbit sanders there are a few things to keep in mind:

- Unlike most sanders, random orbit sanders should be placed on the workpiece BEFORE the tool is started. If the sander is started before it is placed on the workpiece, the free floating pad may be spinning at a speed that can cause scratches when it is finally placed on workpiece.
- Unlike most sanders, random orbit sanders can be moved across the workpiece in any direction (in the case of wood, regardless of the direction of the grain).
- Varying pressure applied to the sander will affect its rotating speed. A light pressure is recommended for fine work, moderate pressure for rough work. Excessive pressure does not allow the pad to rotate enough.
- Keep sanding pad flat on the workpiece. Tipping the sander or using the edges of the pad may produce an uneven finish, and reduce pad life.
- Keep sander moving in broad even strokes across the workpiece. Sanding in one spot too long can cause gouging and uneven results.
- Check the workpiece frequently, random orbit sanders work more aggressively than simple orbital sanders.

⚠WARNING Properly secure workpiece before sanding. Unsecured work could be thrown towards the operator causing injury. Do not wear loose clothing or jewellery when operating sander. They could get caught in moving parts causing serious injury. Keep head away from sander and sanding area. Hair could be drawn into sander causing serious injury.

1. Place sander on the workpiece and turn on the sander.
2. Keep the sanding sheet flat against the workpiece, keep the sander moving across the workpiece, and use long, sweeping strokes.
3. Begin sanding with a coarse grit sandpaper and gradually use finer and finer grits of sandpaper until the desired finish is reached. For example when using the sander on wood, begin with an 80 grit followed by a 120 grit, then a 180 grit and so on.

Removing Paint or Varnish

1. When removing several layers of paint or varnish, remove as much as possible with a paint solvent or varnish remover.
2. Scrape away the residue with a putty knife or other scraping tool and allow the surface to cool and dry before applying sander to the workpiece.

⚠WARNING To reduce the risk of fire and explosion, paint solvents and varnish removers must be removed from the workpiece and the workpiece must be completely dry before sanding.

3. Select a coarse grit sandpaper sheet to help prevent the sandpaper from clogging.
4. Keep the sander moving over new areas to avoid heating and softening the old coating (paint or varnish).
5. Work in wide, overlapping strokes to produce a uniform finish.

6. As the workpiece begins to show through the old coating, switch to a medium grit sandpaper sheet to avoid scratching the surface of the workpiece. Gradually switch to a fine grit sandpaper until you achieve the desired finish.

Emptying the Dust Bag

For more efficient operation, empty the dust bag when it is no more than half full. This will allow the air to flow better through the dust bag. Always empty and clean the dust bag thoroughly upon completion of a sanding operation and before storing the sander.

⚠WARNING To reduce the risk of injury, always wear proper eye protection marked to comply with AS/NZS 1337.1.

To empty the dust bag:

1. **⚠WARNING** Remove battery to avoid starting the tool.
2. Remove the dust bag from the sander.
3. Remove any remaining dust in the dust bag thoroughly by using a suitable dust extraction system.
4. Reattach the dust bag to the sander.

MAINTENANCE

⚠WARNING To reduce the risk of injury, always unplug the charger and remove the battery pack from the charger or tool before performing any maintenance. Never disassemble the battery pack, charger, or tool, except as provided in these instructions. Contact a MILWAUKEE® service facility for all other repairs.

Maintaining Tool

Keep your tool, battery pack and charger in good repair by adopting a regular maintenance program. Inspect your tool for issues such as undue noise, misalignment or binding of moving parts, breakage of parts, or any other condition that may affect the tool operation. Return the tool, battery pack, and charger to a MILWAUKEE® service facility for repair. If the tool does not start or operate at full power with a fully charged battery pack, clean the contacts on the battery pack. If the tool still does not work properly, return the tool, charger and battery pack, to a MILWAUKEE® service facility for repairs.

Cleaning

Clean dust and debris from vents. Keep handles clean, dry and free of oil or grease. Use only mild soap and a damp cloth to clean, since certain cleaning agents and solvents are harmful to plastics and other insulated parts. Some of these include petrol, turpentine, lacquer thinner, paint thinner, chlorinated cleaning solvents, ammonia and household detergents containing ammonia. Never use flammable or combustible solvents around tools.

Repairs

For repairs, return the tool, battery pack and charger to the nearest authorised service centre.

ACCESSORIES

⚠WARNING Use only recommended accessories. Others may be hazardous.

For a complete listing of accessories, go online to milwaukeetool.com.au / milwaukeetool.co.nz or contact a distributor.

WARRANTY - AUSTRALIA and NEW ZEALAND

Please refer to Australian and New Zealand warranty supplied with tool. This warranty applies only to product sold by authorised dealers in Australia and New Zealand.

SERVICE - AUSTRALIA and NEW ZEALAND

MILWAUKEE® prides itself in producing a premium quality product that is Nothing But Heavy Duty™. Your satisfaction with our products is very important to us! If you encounter any problems with the operation of this tool, please contact your authorised **MILWAUKEE®** dealer.

For a list of **MILWAUKEE®** dealers, guarantee or service agents please contact **MILWAUKEE®** Customer Service or visit our website.

(Australia Toll Free Telephone Number 1300 645 928)

(New Zealand Toll Free Telephone Number 0800 645 928)

or visit milwaukeetool.com.au/milwaukeetool.co.nz.

Milwaukee Electric Tool Corporation

13135 West Lisbon Road, Brookfield, Wisconsin U.S.A. 53005

Milwaukee Tool (Australia)

26 - 40 Nina Link, Dandenong South,
Victoria, 3175, Australia

Milwaukee Tool (New Zealand)

274 Church Street, Penrose,
Auckland, 1061, New Zealand

DESIGNED BY MILWAUKEE ELECTRIC TOOL CORP.